

# CONFERENCE

## TOP ACCESS & HOUSING



Conference Top Access & Housing is a perfect solution for boardrooms and meeting tables when you need to access power and media from both sides.

Conference's lid may stay closed while devices are connected. The brushing system allows the cables to run out smoothly while at the same time preventing dust ingress.

When accompanied by the Link, an under-desk power module, Conference offers easy access to the full range of interchangeable multimedia connections, fast chargers and country-specific AC power sockets compliant with the relevant international standards.



THE ACCOMPANYING UNDER DESK POWER MODULE, LINK, COMPLIES WITH BS 5733



TOP ACCESS COLOURS:



### USP

- AVAILABLE IN THREE DIMENSIONS - MIN, MID AND MAX
- QUICK AND EASY INSTALLATION
- TOP ACCESS IS AVAILABLE IN BLACK, WHITE AND SILVER
- 360° USER ACCESS

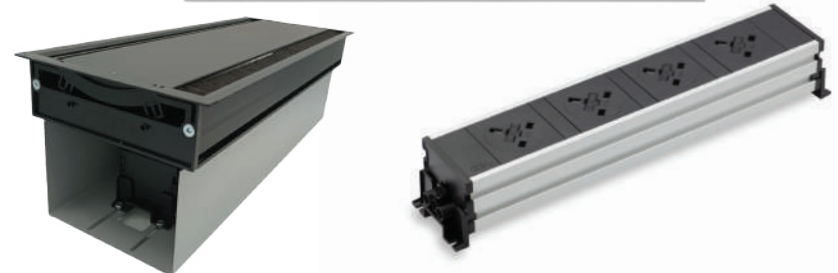
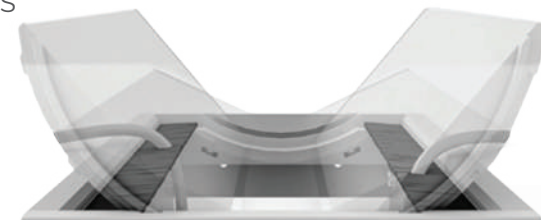

## INSTALLATION

Before making a cutout, please contact your supplier to provide you with a technical drawing stating the relevant table cutout dimensions. Ensure that there is a sufficient clearance, 150mm below the surface and 30 mm between the cutout edge and the edge of the work surface.

STEP 1: Place the Conference into the table cutout

STEP 2: Place the fixing point into the sliding channel

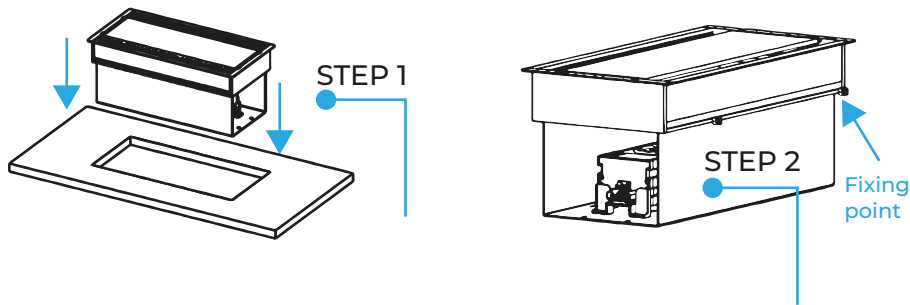

STEP 3: Place the L tighteners onto the fixing points

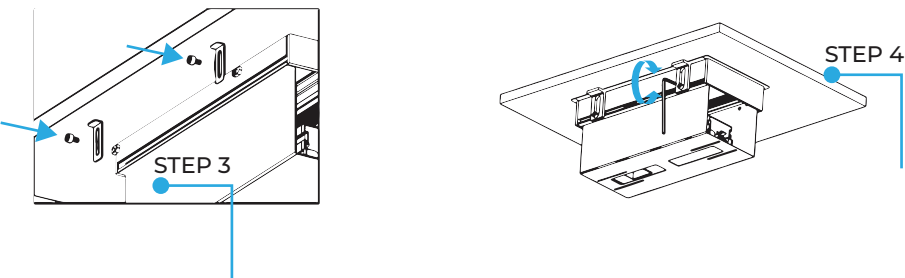

## DIMENSIONS

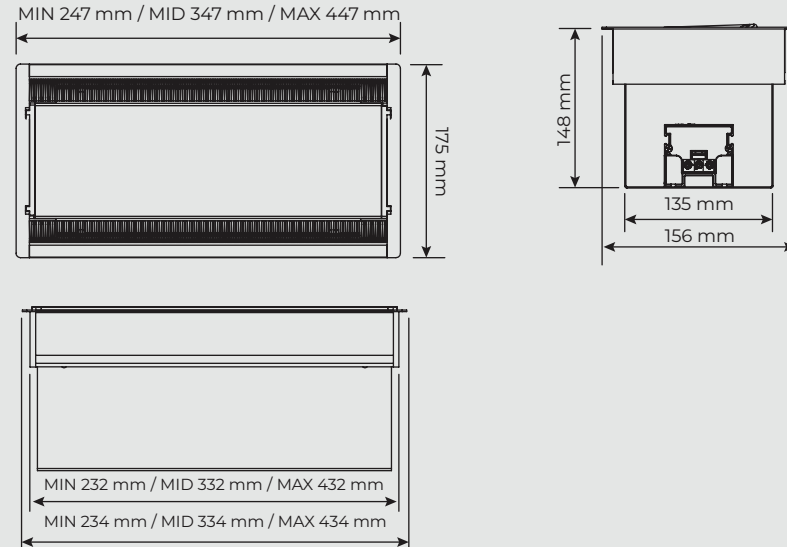

### TABLE CUTOUT AVAILABLE LINK CONFIGURATION

<b>G SOCKET TYPE</b>  <b>OR</b> <b>UNIVERSAL SOCKET TYPES</b>	MIN 156mm x 234mm	UP TO TWO SOCKETS OR IMP SLOTS
	MID 156mm x 334mm	UP TO THREE SOCKETS WITH USB CHARGER/IMP SLOT, OR TWO SOCKETS WITH TWO USB CHARGERS/IMP SLOTS
	MAX 156mm x 434mm	UP TO FIVE SOCKETS OR SIX IMP SLOTS
<b>OTHER SOCKET TYPES</b>	MIN 156mm x 234mm	UP TO TWO SOCKETS OR IMP SLOTS
	MID 156mm x 334mm	UP FOUR SOCKETS OR IMP SLOTS
	MAX 156mm x 434mm	UP TO SIX SOCKETS OR IMP SLOTS